

SERIE PSM2

ELECTROBOMBAS CENTRÍFUGAS MONOBLOC DIN 24255 EN ACERO INOX AISI 316 2.900 rpm

PRESTACIONES

Altura manométrica hasta 111 m

Caudal hasta 3.800 l/min (228 m³/h)

LÍMITES DE EMPLEO

Temperatura del líquido -20 °C hasta +110 °C

Presión de trabajo máx. 10 bar

CARACTERÍSTICAS DE EMPLEO E INSTALACIÓN

Electrobombas monobloc, construidas totalmente en **acero Inox AISI 316 L**, y según la **norma DIN 24255**. Aptas para trasiego de **líquidos limpios** y químicamente compatibles con el acero Inox. Indicadas para instalaciones de riego, climatización, equipos de presión y contra incendios, etc.

Los motores deberán protegerse con un guardamotor adecuado.

CARACTERÍSTICAS DE CONSTRUCCIÓN

CUERPO DE BOMBA, RODETE, Y DISCO PARA CIERRE: En **acero Inox AISI 316**

EJE BOMBA: En **acero Inox AISI 316**

SELLO MECÁNICO: **Cerámica - grafito**, según **DIN 24960**

MOTOR ELÉCTRICO: **Asíncrono**, con ventilación externa, apto para servicio continuo, aislamiento clase F, protección **IP55** A 230/400 V, hasta 5,5 CV y 400/700 V a partir 7,5 CV.

CONEXIONES:

PSM32 Aspiración: 50 mm - Impulsión 32 mm

PSM40 Aspiración: 65 mm - Impulsión 40 mm

PSM50 Aspiración: 65 mm - Impulsión 50 mm

PSM65 Aspiración: 80 mm - Impulsión 65 mm

PSM80 Aspiración: 100 mm - Impulsión 80 mm



TABLA DE PRESTACIONES

MODELO	Potencia		Amperios		Q m³/h l/min	6	9	12	15	18	24	30	36	42	48	60	72	84	
	kW	CV	3-230 V	3-400 V		100	150	200	250	300	400	500	600	700	800	1000	1200	1400	
PSM2-32/125B	0,75	1	3,2	1,85	H mts	16	14	13	11	10									
PSM2-32/125A	1,1	1,5	4,5	2,6		21	20	18	16	14									
PSM2-32/160B	1,5	2	6,2	3,6		25	24	22	20	17	10								
PSM2-32/160A	2,2	3	8,5	4,9		34	33	31	29	26	12								
PSM2-32/200B	3	4	11,2	6,5		41	39	36	33	30	21								
PSM2-32/200A	4	5,5	14,7	8,5		51	49	47	44	41	21								
PSM2-32/250C	5,5	7,5	20	11,5		56	53	51	48	45	32								
PSM2-32/250B	7,5	10	26,8	15,5		71	69	66	63	60	37								
PSM2-32/250A	11	15	38	22		83	80	78	74	71	52								
PSM2-40/125C	1,1	1,5	4,5	2,6					14	13	63		8						
PSM2-40/125B	1,5	2	6,2	3,6					17	17	11	10	11	8					
PSM2-40/125A	2,2	3	8,5	4,9					23	22	14	13	16	13					
PSM2-40/160B	3	4	11,2	6,5					31	30	21	18	21	17					
PSM2-40/160A	4	5,5	14,7	8,5					37	36	27	24	27	23					
PSM2-40/200B	5,5	7,5	20	11,5					48	46	33	30	36	31					
PSM2-40/200A	7,5	10	26,8	15,5					56	55	44	41	45	40					
PSM2-40/250C	11	15	38	22					63	62	53	49	52	45					
PSM2-40/250B	11	15	38	22					72	71	60	56	61	55					
PSM2-40/250A	15	20	52	30					85	84	69	66	74	69	63				
PSM2-50/125C	2,2	3	8,5	4,9								16	15	14	12	10	7		
PSM2-50/125B	3	4	11,2	6,5								20	19	18	16	14	11		
PSM2-50/125A	4	5,5	14,7	8,5								24	23	22	21	18	15	12	
PSM2-50/160B	5,5	7,5	20	11,5								32	31	29	28	24	20	15	
PSM2-50/160A	7,5	10	26,8	15,5								39	38	36	35	31	27	22	
PSM2-50/200B	11	15	38	22								50	48	45	43	37	30	21	
PSM2-50/200A	11	15	38	22								57	55	53	50	44	37	28	
PSM2-50/250C	15	20	52	30								68	67	65	63	58	51		
PSM2-50/250B	18,5	25	63	36,4								76	75	73	71	66	60		
PSM2-50/250A	22	30	74,4	43								86	85	83	81	76	69	61	

MODELO	Potencia		Amperios		Q m³/h l/min	48	60	72	84	96	108	120	150	180	210	228	
	kW	CV	3-230 V	3-400 V		800	1000	1200	1400	1600	1800	2000	2500	3000	3500	3800	
PSM2-65/160E	4	5,5	14,7	8,5	H mts	17	15	14	12	10	8						
PSM2-65/160D	5,5	7,5	20	11,5		21	20	18	16	14	12						
PSM2-65/160C	7,5	10	26,8	15,5		26	25	23	21	19	17	15					
PSM2-65/160B	11	15	38	22		35	33	30	27	24	20						
PSM2-65/160A	11	15	38	22		41	39	36	33	29	26	21					
PSM2-65/200C	15	20	52	30		50	48	45	41	37	32						
PSM2-65/200B	18,5	25	63	36,4		58	55	52	49	45	40	35					
PSM2-65/200A	22	30	74,4	43		66	63	60	57	54	49	42					
PSM2-65/250B	30	40	102	59		83	82	80	77	73	69	64					
PSM2-65/250A	37	50	124	71,5		97	94	93	90	86	82	78					
PSM2-80/160C	11	15	38	22				32	31	29	28	26	21	15			
PSM2-80/160B	15	20	52	30				39	38	36	35	33	28	22	15		
PSM2-80/160A	18,5	25	63	36,4				46	45	43	42	40	35	29	23	20	
PSM2-80/200C	22	30	74,4	43					51	49	48	45	41	35	29		
PSM2-80/200B	30	40	102	59					62	61	59	58	52	47	40	35	
PSM2-80/200A	37	50	-	71,5					70	69	68	66	61	56	49	44	
PSM2-80/250C	45	60	-	88					81	80	78	76	70	63	54		
PSM2-80/250B	55	75	-	106					94	93	91	89	83	77	68		
PSM2-80/250A	75	100	-	134					111	109	108	106	101	94	86	80	

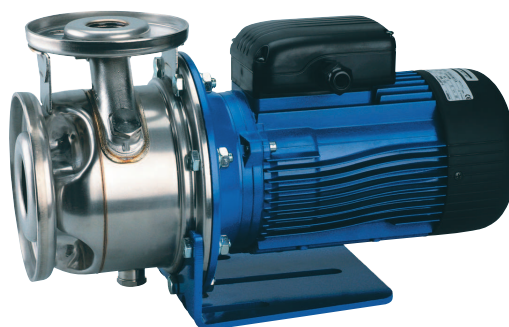

GRÁFICO DE DIMENSIONES

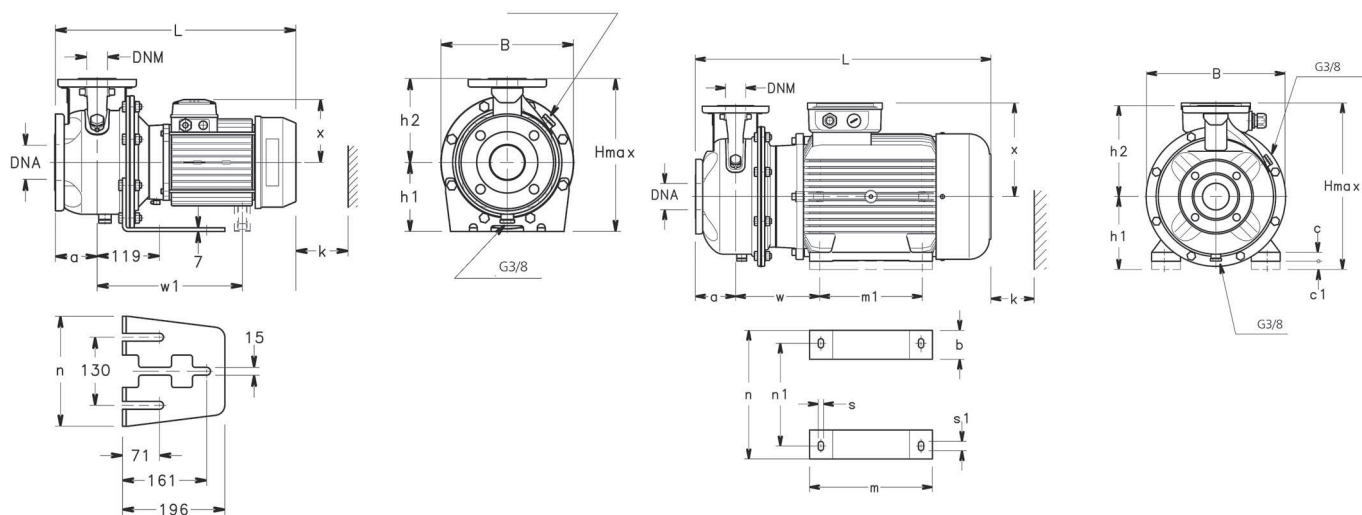

TABLA DE DIMENSIONES

MODELO	DNM	DNA	a	h2	w	x	b	c	c1	h1	m	m1	n	n1	s	B	H	L																
PSM2-32/125B	32	50	80	140		116				112			190			218	252	432																
PSM2-32/125A																																		
PSM2-32/160B																																		
PSM2-32/160A					100	160		121			132			210			253	292	461															
PSM2-32/200B						180		133			160			230			285	340		487														
PSM2-32/200A						225		150			180			265			345	405		553														
PSM2-32/250C					100	225		191				180			265			345	405	604														
PSM2-32/250B								208													232	72	22	20	180	260	210	318	254	13	412	688		
PSM2-32/250A																																		604
PSM2-40/125C	40	65	80	140		116				112			190			219	252	432																
PSM2-40/125B																																		
PSM2-40/125A																																461		
PSM2-40/160B					100	160		121			132				210			254	292	487														
PSM2-40/160A						180		133			160			230			285	340	553															
PSM2-40/200B						225		150			180			265			345	405	604															
PSM2-40/200A					100	225	208	232	72	22	20	180	260	210	318	254	13	345	412	688														
PSM2-40/250C																																		
PSM2-40/250B																																		
PSM2-40/250A																		732																
PSM2-50/125C	50	65	100	160		121				132			210			254	292	481																
PSM2-50/125B																																		
PSM2-50/125A																																507		
PSM2-50/160B					100	180		150			160							255	340	553														
PSM2-50/160A						200		191			160			245			310	360	604															
PSM2-50/200B						225	208	232	72	22	20	180					318	254	13	345	412													
PSM2-50/200A					100	225	208	232	72	22	20	180	260	210	318	254	13	345	412	688														
PSM2-50/250C																																		
PSM2-50/250B																																		
PSM2-50/250A																		507																
PSM2-65/160E	65	80	100	200		133				160			245			310	360	553																
PSM2-65/160D																																		
PSM2-65/160C																																		604
PSM2-65/160B					100	225	208	132	72	22	20	180	260	210	318	254	13	345	412	688														
PSM2-65/160A																																		
PSM2-65/200C																																		
PSM2-65/200B					125	250	208	232	72	22	20	180	260	210	318	254	13	345	430	713														
PSM2-65/200A																																		
PSM2-80/160C																																		
PSM2-80/160B	80	100	125	250	208	232	72	22	20	180	304	254	318	254	13	345	430	757																
PSM2-80/160A																																		
PSM2-80/200A																																		