

TABLA DE DIMENSIONES

MODELO	Figura	DIMENSIONES (mm)																												
		A	A'	A''	B	C	D	E	F	F'	G	H	H'	I	J	K	L	M	N	O	P	Q	R	S	T	U	V	W	X	
SKS 50	1	198			219	80	79		158,5	220		120		26		29			22	28	1 ^{1/4"}	54,5	4,2							PG11
SKS 80		245			249	92	205	227	226		119	130		29	114,5	83	108	70,5	72,5	40	1 ^{1/4"}	64	Ø10	2,3			140	129	1/2"	
SKS/SKH 140		284			300	115	225	253	238		107	152			124	95	130	68,5	74,5	42,5	1 ^{1/2"}	68	Ø12	3			174	156	1/2"	
SKS 250		332			338	122	260	296	300		152	176		25	134	115	155	102	83	44	2"	83	Ø14	4			200	158	1/2"	
SKH 300		383			415	125	290	330	338		156,5	196		25	160	140	180	92	106	51	2"	83	Ø15	4	42		240	171,5	3/4"	
SKS 475		466			556	147	365	422	461,5		163	270		31	180	280	316	155	26,5	84	2 ^{1/2"}	Ø128	16	28	42		408	263	3/4"	
SKS 550		466			556	147	365	422	461,5		163	270		31	180	280	316	155	26,5	84	2 ^{1/2"}	Ø128	16	28	42		408	263	3/4"	
SKS 100		2	560			630	210	360	414	663	710	163	305		35	211	600	631,5		96	95	4"	150	16	25,5	55		490	402,5	1"
SKS 80 2V	3	284	303		272	46	205	227	293		117	130	110	29	114,5	83	108	73	136,5	40	1 ^{1/4"}	64	Ø10	2,3		89	140	192	1/2"	
SKS 156 2V		321	315,5		312,5	57,5	225	253	314		152	152	152		134	95	130	68,5	150,5	42,5	1 ^{1/2"}	68	Ø12	3		104,5	174	238	1/2"	
SKS 222 2V		364	417,5		371	61	260	296	385,5		156,5	176	141	25	160	115	155	102	168,5	44	2"	83	Ø14	4	42	110,05	200	258	3/4"	
SKS 400 2V		424	427		415	62,5	290	330	434		156,5	196	158	25	160	140	180	92	202	51	2"	83	Ø15	4	42	126,5	240	267,5	3/4"	
SKS 475 2V		424	427		415	62,5	290	330	434		163	196	158	25	180	140	180	92	202	51	2"	83	Ø15	4	42	126,5	240	352,5	3/4"	
SKH 570 2V11	4	486	372	307	556	144	365	422	700		313	270	190	31	211	280	316	265	155	109	2 ^{1/2"}	Ø128	16	28	55	59,5	408	379	1"	

DIMENSIONES SIMPLE ETAPA

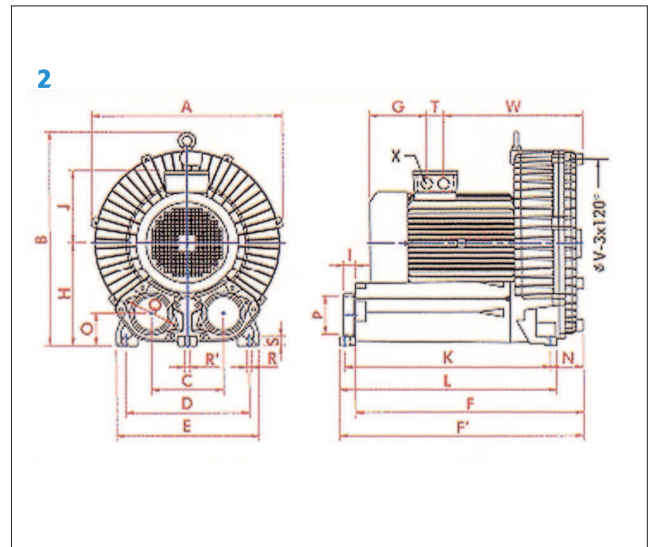
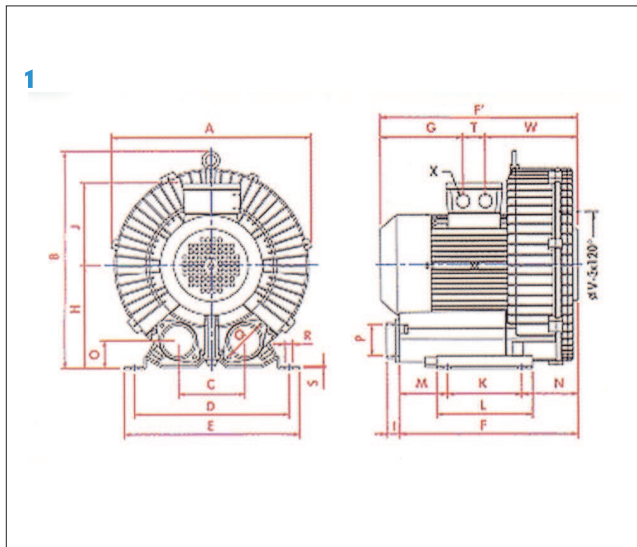

DIMENSIONES DOBLE ETAPA

